



Owner's Manual

VENTURE
50



-



INTRODUCTION

Thank you for purchasing the "Venture 50" from the Genuine Scooter Company. The efficiency and longevity of each scooter will depend heavily on the operating methods and periodic maintenance of each user.

This owner's manual will provide you with operating instructions, precautions, and general maintenance information required to safely operate and maintain your scooter.

Your safety, and the safety of others, is an important responsibility. When you see the safety messages displayed on the right throughout this manual, pay close attention.

Your Genuine Scooter dealer is the primary resource for information, parts and service. If you have any questions, please ask your dealer for assistance.

Safety symbols and notes

Please observe the following:

FIRE HAZARD

The vehicle is equipped with a catalyst, this results in extremely high temperatures on the exhaust system (risk of burning).

WARNING

Precautionary measures against the risk of accidents, injury and/or death.

CAUTION

Important instructions and precautionary rules to avoid damage to the vehicle. Non-observance can lead to the warranty becoming void.

NOTE

Special instructions for better handling during operation-, inspection-, adjustments and service activities.

CONTENTS

OVERVIEW AND OPERATION

Identification number, engine number 3
View of vehicle 4 - 5
Cockpit, handlebar instrument 6
Ignition lock and fork-column lock 7
Storage box, luggage hook 8
Fuel, fuel stock, coolant temperature warning light 9
Tank cap 10
Coolant level 11
Side stand, parking stand 12

SAFETY TEST

Checklist 13
Load and lights 14

RIDING INSTRUCTIONS

Ride safely 14
Ride economically and environmentally 15
Running-in instructions 16
Starting 17 - 18
Brakes 19 - 20
Stopping the engine 20

SERVICE INSTRUCTIONS

Servicing the scooter / cleaning agents 21 - 22
Winter operation and corrosion protection 22
Repairing paint damage / servicing the tires 23
Lay-up commission 23
Technical modifications, accessories and spare parts 24

CONTENTS

NOTES ON MAINTENANCE

Engine oil level, clean oil filter element.....	25
Fill engine oil, transmission oil	26
Checking steering bearing, telescopic fork.....	27
Tires	28
Front wheel brake	29 - 30
Rear wheel brake	31 - 32
Adjusting the play of the twist grip throttle control	33
Cleaning the air filter.....	34 - 36
Checking the spark plug	37
Fuse	38
Battery	39 -40
Changing the light bulbs	41- 46
Adjusting the headlight	47

TECHNICAL DATA

Engine	48
Power transmission	49
Chassis.....	49
Lubricants and operating fluids	50
Electrical equipment	50
Dimensions and weights.....	51

WARRANTY AND SERVICE DATA

Warranty conditions.....	52
List of wear items.....	53 - 54
Inspection plan	55 - 57
Proof of maintenance	58 - 59

SUMMARY AND OPERATION

Identification number

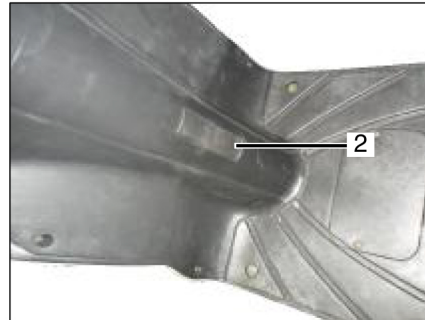

Engine number



 **NOTE**

The description for right and left-hand side is viewed from the driver's perspective on the vehicle.

The Vehicle Identification Number (1) is located on the frame below the right side cover.

The Vehicle Identification Number is also located on the frame behind the cover (2).

The engine number (3) is located on the left-hand side.

Key: Two keys are provided and are designed to operate the following:

-Ignition lock, and under-seat storage area.

Keep the spare key in a safe place.

OVERVIEW AND OPERATION

Right-hand side view

- 1 Storage box with tool kit
- 2 Luggage hook
- 3 Cover for coolant
- 4 Battery box and fuse
- 5 Ignition- and fork-column lock
- 6 Brake fluid container for front brake
- 7 Handbrake lever for front brake
- 8 Spark plug



OVERVIEW AND OPERATION

Left-hand side view

- 9 Handbrake lever for rear brake
- 10 Cockpit
- 11 Fuel Tank cap
- 12 Transmission oil filter plug
- 13 Kick starter
- 14 Parking center-stand
- 15 Air filter
- 16 Side stand





OVERVIEW AND OPERATION



Cockpit



Instruments



- 1 Speedometer
- 2 Odometer
- 3 Fuel indicator 
- 4 Coolant temperature indicator 

Instrument lights

- 5 Left and right direction  green
- 6 High beam indicator  blue

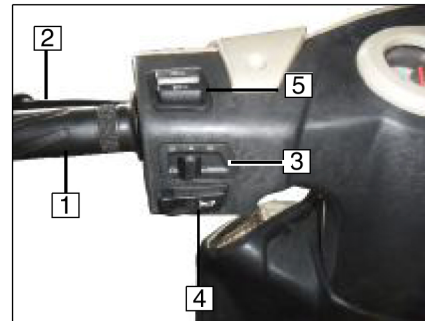

Handlebar instrument, left

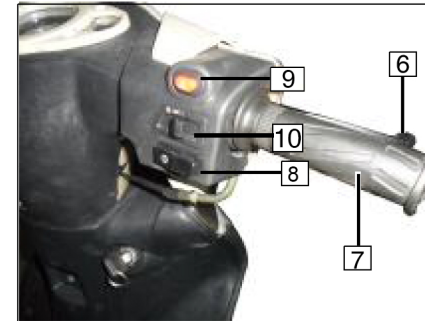

- 1 Hand grip
- 2 Handbrake lever for rear brake
- 3 Direction-indicator switch
 - ⇐ Switch to the left: Left indicator on
 - ⇒ Switch to the right: Right indicator on
 - Push button for switch off
- 4  Push-button: horn
- 5 High beam switch
 -  High beam
 -  Low beam

Handlebar instrument, right



- 6 Handbrake lever for front brake
- 7 Throttle
- 8  Starter button
- 9  Hazard warning lamp switch
- 10 Engine Kill Switch

Ignition- and fork-column lock

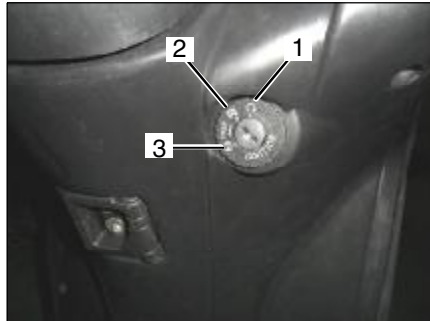

Key positions



NOTE

Activate the parking light only for a limited period of time. Take into account the charge of the battery.

The key can be removed in positions  and



(1) Operating position

Ignition and all circuits activated.



(2) Ignition off

Fork column not locked (handlebars can be freely turned to the left or right).



(3) Fork column locked and Ignition off

Turn the handlebar to the left as far as to the stop.

Push and turn the key to the left until it is in the LOCK  position. The fork column is now locked.



WARNING

While riding, do not switch the ignition off  !



NOTE

Keys:

Two keys are supplied with your vehicle.

Keep the spare key in a safe place.

OVERVIEW AND OPERATION

Storage box

- Do not store valuables in the box.
- Make sure that the seat has been locked completely after it was pressed down.
- Take out valuables before washing to avoid wetting these objects.
- Do not place thermal sensitive objects in the box because of the engine's heat and high temperature.



Unlock

- Insert the ignition key (1) into the lock, turn and press down the key to the right or left direction (OPEN).

Lock

- Press down the seat (2) until the lock is engaged.
- Pull out the ignition key.

Never leave the key in the storage box.



WARNING

After the seat is closed, check to ensure that it is locked firmly! Failure to lock the seat could result in an accident!

Maximum load capacity: 22 lbs

Luggage hook

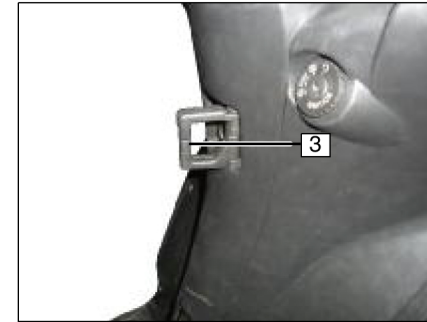

Use the hook (3) only for small baggage pieces.



WARNING

Maximum load capacity: 3.5 lbs

Do not transport bulky loads on the bag hook!

Fuel, fuel tank

⚠ WARNING

Fuel is highly flammable and can explode. Do not smoke or bring an open flame near the fuel tank.

Fuel expands under the influence of heat and the sun. Therefore, never fill the tank to the brim. Never fill the tank while the engine is running.

Never bring a glowing cigarette or open flame near an open tank, because fuel vapour could suddenly ignite.

Fuel Indicator



👉 NOTE

The fuel indicator (1) is active when the ignition is turned on.

The scale with the tank symbol 

E = Empty

F = Full

Don't run down the fuel tank level to empty.

Fuel Grade

- Use only premium lead-free fuel (minimum 93 octane) in this vehicle.

Coolant temperature warning light



👉 NOTE

If the coolant temperature indicator (2) has reached the red area, the coolant temperature is too high indicating a problem.

At this time, stop the scooter immediately and then turn off the engine, letting it cool down.

👉 CAUTION

Do not run the engine if it has overheated, otherwise the engine will become damaged!

OVERVIEW AND OPERATION

Fuel Tank cap

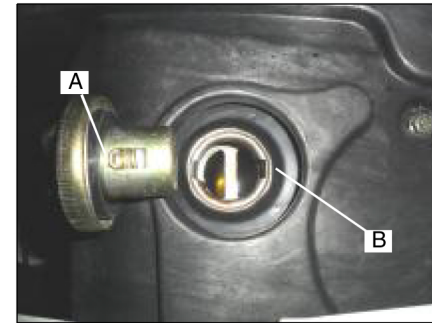
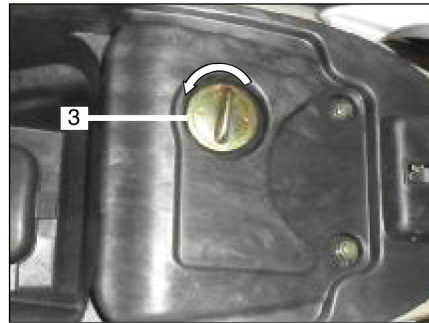
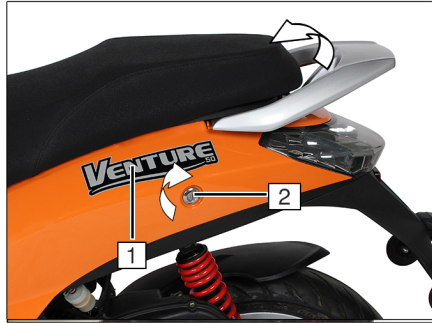

NOTE

The tank cap is located underneath the rear part of the seat (1).

Unlock:

- Insert the ignition key into the lock (2) and turn the key to the right, open the seat.
- Turn the tank cap (3) counter-clockwise and open the tank cap.

Lock:

- Align A to B, press the tank cap and turn it clockwise.
- Press down the seat until the lock is engaged.
- Pull out the key.

Coolant level

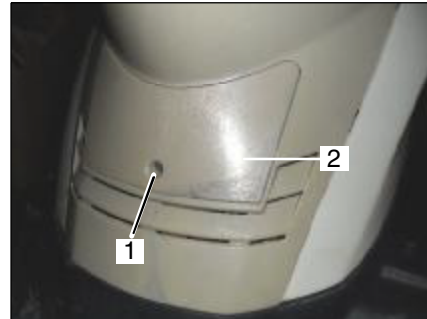
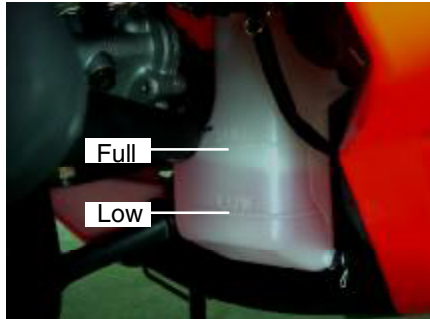

 **CAUTION**

Check the coolant level during every refueling and replenish if necessary. Please keep the coolant level between the Low and Full indicators as shown above.

Damage caused by not observing this instruction will not be covered under warranty.

Filling up with coolant

- Fill the recommended coolant to the proper level.

Recommended coolant: High-quality antifreeze containing corrosion inhibitors for aluminum engines.

Mixing ratio: 4:6 (antifreeze: water)

Coolant reservoir capacity: 0.5 L (Max.-marking)

 **CAUTION**

Use only distilled water when mixing with coolant.

- Remove the screw (1).
- Open the inspection cover (2).
- Open the filler cap (3) and replenish the coolant to the proper level.
- Tighten the filler cap by hand
- Close the inspection cover (2)

OVERVIEW AND OPERATION

Side stand and parking stand

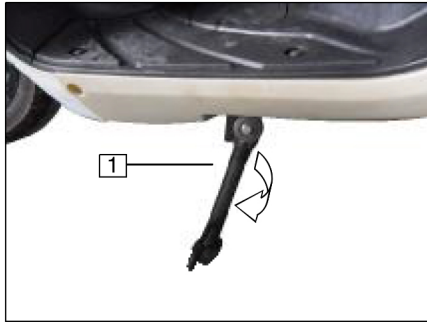

Propping up the scooter on the side stand.

⚠ WARNING

Always make sure that the stand is resting on firm ground. On sloping roads, always park the scooter facing uphill.

It is essential that the side stand is folded up before starting off!

Side stand



Switch off the engine.

- Put your left hand on the left handlebar grip.
- Fold out the arm of the side stand (1) as far forward as it will go and stop by foot.
- Slowly tilt the scooter to the left until its weight is supported.

Parking stand

- Switch off the engine.
 - Put your left hand on the left-hand handlebar grip.
 - Hold with your right hand the grab rail (3).
- Push the parking center-stand (2) down until the two skids are on the ground.
 - Put your full body weight on the operating mandrel of the main stand.
- Pull the scooter towards the rear and simultaneously upwards onto the parking stand.
- Check that the scooter is standing firmly.

Checklist

Before each ride, carry out a safety check using the checklist.

Take this safety check seriously. Carry out maintenance activities before you start your ride or ask a specialized dealer to do so. This will provide you with the certainty that your scooter corresponds to traffic regulations. A technically sound scooter is a basic requirement for the safety of both yourself and other road users.

Before starting your ride, check the following:

- Steering (smooth and free of play)
- Clutch lever play
- Engine oil quantity
- Coolant quantity
- Fuel quantity
- Front brake
- Rear brake
- Tires (profile and pressure)
- Telescopic fork
- Load / lights
- Total weight
- Lights
- Brake fluid (level)
- Brakes (operation)

In case of problems or difficulties, contact a dealer, who will do everything possible to assist you.



WARNING

While the engine is running or the ignition is on, do not touch the ignition system.



FIRE HAZARD

The exhaust system becomes very hot. While riding, idling or parking, make sure that no inflammable materials (e.g. hay, leaves, grass, coverings or luggage, etc.) can come into contact with it!

SAFETY TEST

Load / lights

WARNING

For the sake of your safety, use only original Genuine Scooter Company parts and accessories or products approved by us.

We cannot judge whether each third-party product can be safely used in combination with your scooter. Nor can an official approval give such a guarantee in all cases, since the test scope is not always sufficient.

NOTE

Our accessories and approved products as well as qualified advice are available from all specialized dealers.

Correctly loaded

- Make sure that the left-right weight distribution is balanced.
- Check that fastenings are correct and tight.
- Do not transport bulky loads.
- Do not cover the lights.

WARNING

**The total allowable weight may not be exceeded.
Check the tire pressure.
Check the lights.**

WARNING

Before any ride, check the operation of all lighting components.

- Check that the headlamps and lenses are clean.

Ride safely

CAUTION

Riding safety is largely determined by the manner of riding.

Therefore:

- Put on a DOT approved safety helmet and correctly close the buckle.
- Wear suitable protective clothes.
- Rest your feet on the footrests.
- Do not ride if your riding ability has been compromised.

Your reactions can be adversely affected not only by alcohol, but also by drugs and medicines. Do not operate the scooter under the influence of drugs or alcohol.

- Strictly observe all traffic regulations.
- Always adapt your riding speed to the traffic and road conditions.

On smooth, slippery roads take into account that your riding stability and braking power are limited by the grip of the tires on the road surface.

Ride economically and be aware of the environment

Fuel consumption, environmental pollution and wear of the engine, brakes and tires depend on various factors. Your personal riding style is highly determinate for economical fuel consumption, exhaust gas and noise generation.

While idling, the engine takes a long time to warm up to operational temperature. In the warm-up phase, however, the wear level and pollutant emissions are very high. It is therefore best to start riding immediately after start-up.

Avoid rapid acceleration

Open the throttle not further than needed, in order to reduce fuel consumption as well as pollution and wear levels.

Do not use excessive revs; change up as soon as possible and do not change down until it is necessary to do so.

Ride as evenly as possible and look ahead as far as possible.

Unnecessary acceleration and hard braking cause high fuel consumption and increased pollution levels.

Turn the engine off when waiting in traffic.

Different riding conditions affect fuel consumption. The following conditions are unfavorable for fuel consumption:

- High traffic density, especially in big cities with many stops for traffic lights.
- Frequent short rides with repeated starts and warm-ups of the engine.
- Riding in a column of scooters at low speed, meaning riding with relatively high revs.

Plan rides ahead of time in order to avoid heavy traffic.

Fuel consumption is also affected by conditions that are out of your control, for instance, poor road conditions, hills, riding in winter.

Observe the following aspects for economical fuel consumption:

- The planned inspection intervals must be closely observed.
- Regular service by a specialized dealer will guarantee not only continued operability, but also economical fuel consumption, low environmental pollution and a long lifespan.
- Check the tire pressure every two weeks

Low tire pressure increases rolling resistance. This increases fuel consumption and tire wear and adversely affects riding behavior.

- Continually check fuel consumption.
- Frequently check the oil.

RIDING INSTRUCTIONS

Running-in

Running-in instructions for engine and transmission

 **CAUTION**

Excessive revs while running-in the engine increases the wear of the engine. Engine faults during the running-in period must be immediately reported to a specialized dealer.

 **NOTE**

During the running-in period, ride in frequently changing load and rpm ranges. Select winding and slightly hilly routes. Avoid constantly low rpm counts and full throttle under load.

- **During the first 250 miles:**

Less than 1/2 throttle.

- **Up to 500 miles:**

Less than 3/4 throttle.

 **CAUTION**

The first inspection must be carried out immediately after the first 500 miles.

You can save yourself delays by making an appointment with a specialized dealer in advance.

Running-in new tires

 **CAUTION**

New tires have a smooth surface and are often covered in release agent. The tires must therefore be roughened by carefully running them in at various slanted positions.

Only then will the tire surface obtain its full grip!

Running-in new brake linings

 **WARNING**

New brake linings must be run-in and will not have their full friction power until after 250 miles.

The slightly reduced braking effect can be compensated for by an increase in pressure on the brake lever.

During this period, avoid unnecessary hard braking actions!

Starting with the electric starter

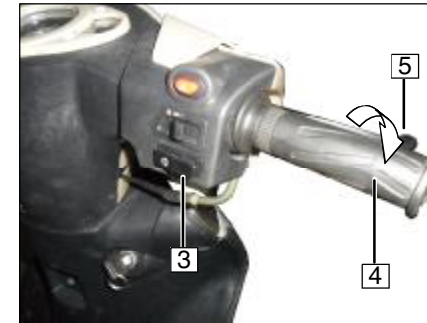
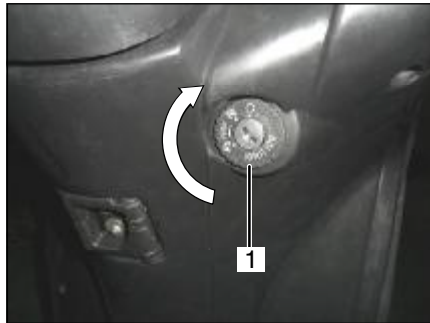

WARNING

Prop up the scooter with the parking stand. Operate the rear handbrake lever to avoid movement of the scooter. Avoid high engine rpm's while the vehicle is standing still, otherwise the clutch will engage.

NOTE

The tank cap is located behind the rear part of the seat (1).

Before starting

- Prop up the scooter with the center stand.
- Turn the ignition lock (1) with the ignition key to its operating position ↻.
- Do not open the throttle (4).
- Pull and hold either brake lever (2) or (5).
- Operate the start button ⏻ (3).
- If the engine can not be started after the starter motor is running for 3-5 seconds, open the throttle (4) 1/8 - 1/4 turn and start again.
- Push the scooter off its parking stand.
- Mount the scooter.
- Release the brake before riding.

CAUTION

If the engine won't start immediately, release the start button, wait a few seconds and push it again. Each time, push the start button for just a few seconds in order to save the battery. Never push the start button for more than 10 seconds.

WARNING

Never allow the engine to run in an enclosed space. Exhaust gases are highly toxic and can kill.

RIDING INSTRUCTIONS

Starting with kick starter

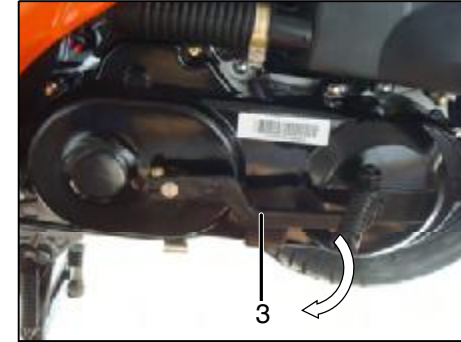
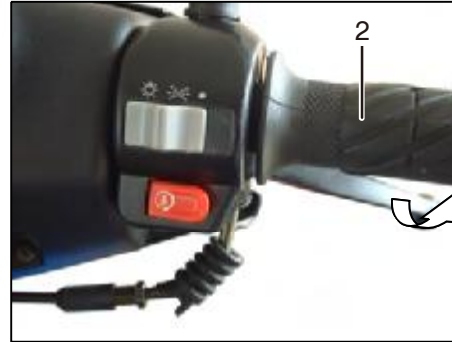
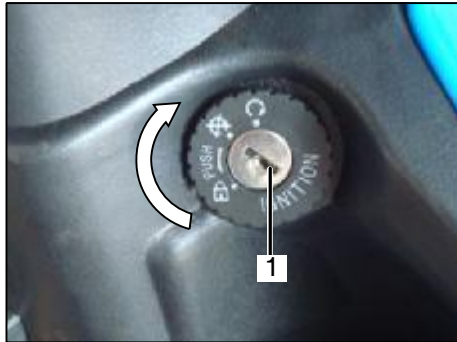

 **CAUTION**
After starting the engine, check that the kick starter lever (3) is returned to its normal position.

- Propping up the scooter when operating the kick starter.
- Turn the ignition lock (1) with the key to its operating position ↻.
- Do not open the throttle (2).
- Depress the kick starter lever (3) quickly and the engine will start.
- After the engine is running return the kick starter lever to its normal position.

 **NOTE**
Use the kick starter from time to time to maintain its function.

Braking

Wet brakes

Washing the scooter or riding through water or rain can delay the braking effect due to wet or (in winter) ice-covered brake discs and linings.



The brakes must first be operated until they are dry.

Salt film on the brakes

When riding on salted streets without braking for a while, the full braking effect may be delayed.

Oil and grease



The brake discs and linings must be free of oil and grease!

If the scooter is not used for a while, a rust film may form on the brakes and thus increase the braking effect. A thick rust film can cause the brakes to lock up. When setting out on a ride after a long lay-up period, carefully operate the brakes several times until they work normally.



Make sure you practice braking for emergency situations, but do so where you will not pose a risk to yourself or others (e.g. a deserted parking area).



Operate the brakes to grind off the salt deposited on the brake discs.

Dirty brakes

When riding on dirty streets, the braking effect can be delayed due to dirty brake discs and linings.



Operate the brakes until they are clean. Lining wear is increased by dirty brakes!

RIDING INSTRUCTIONS

Braking

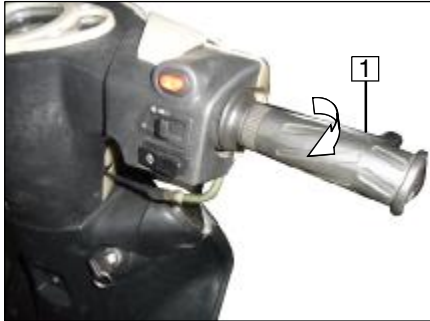

Braking

The front brake and rear brake are operated independently from each other.

The front brake is operated via the right-hand brake lever (1) on the handlebars, and the rear brake is operated via the left-hand brake lever (2).

When stopping or slowing down, release the throttle gas and operate **both** brakes at the same time.

On tight curves, sandy / dirty streets, wet asphalt and icy roads, use the front brake carefully: if the front wheel locks, the bike will slide sideways.

Brake with care. Locked wheels do not have much braking effect and can lead to skidding / crashing. In principle, do not brake on a curve, but before the curve.

Braking on a curve increases the danger of sliding.

Stopping the engine



- Turn the ignition lock (3) with the ignition key to the position .

- Pull out the ignition key.

SERVICE INSTRUCTIONS

Servicing the scooter / cleaning agents

 **NOTE**

Regular, expert service will help maintain the value of your motorcycle and is a condition for guarantee claims for corrosion and other such damage.

 **CAUTION**

Rubber and plastic parts will be damaged by caustic or penetrating cleaning agents or solvents.

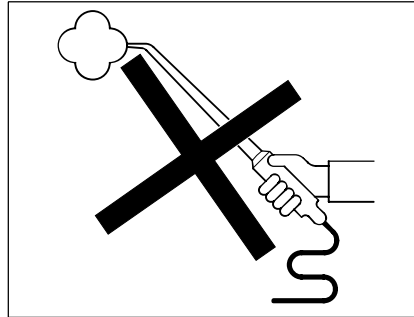

 **WARNING**

Always carry out a brake test after cleaning and before starting a ride!

 **CAUTION**

Do not use steam or high-pressure jet devices!
Such devices can damage seals, the hydraulic braking system and the electrical system.

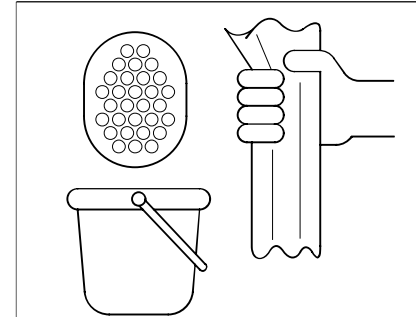

CLEANING

- To wash the motorcycle, use a soft sponge and clean water.
- Afterwards, dry off with a polishing cloth or chamois.
- Do not wipe off dust or dirt with a dry cloth, to avoid scratching the paint or covering.

SERVICE INSTRUCTIONS

Servicing the scooter / cleaning agents

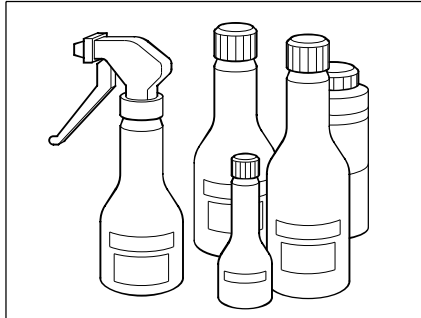

PRESERVATION AGENTS

When necessary, the motorcycle must be preserved with commercially available preserving and cleaning agents.

- By way of precaution (especially in winter), regularly treat parts liable to corrosion with preservation agents.

CAUTION

Never use paint-polishing agents on plastic parts.

- After a long ride, thoroughly clean the chassis and the aluminium parts and preserve them with a commercially available anti-corrosion agent.

Operation in winter and anti-corrosion protection

NOTE

Protect the environment by using only environmentally friendly preservation agents, and use them frugally.

Use of the vehicle in the winter can cause considerable damage due to the presence of salt on the roads.

CAUTION

Do not use hot water, which would increase the corrosion effect of the salt.

- At the end of each ride, wash the scooter with cold water.
- Thoroughly dry the scooter.
- Treat parts liable to corrosion with wax-borne anti-corrosion agents.

SERVICE INSTRUCTIONS

Repairing paint damage

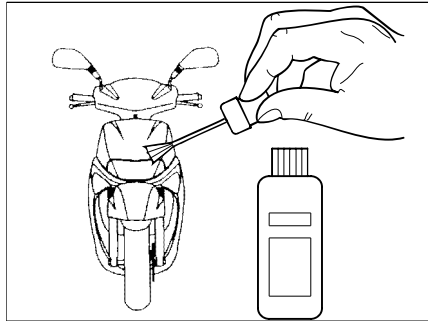

Minor paint damage should be immediately repaired.

Servicing tires

If the scooter is not used for a long period, it is recommended to support the scooter so that its weight is not on the tires.

You can prevent the tires from becoming dry and brittle by spraying them with a silicone-rubber treatment. First, thoroughly clean the tires.

Do not store the scooter or the tires in hot spaces (such as a boiler room) for long periods.



WARNING

A minimum tire-profile depth of 2.0 mm must be maintained at all times.

Long-term Storage

Storage

- Clean the scooter
- Remove the battery
- Observe the maintenance instructions.
- Spray suitable lubricants onto the brake-lever and clutch lever joints and the side-standard and main-standard bearings.
- Rub bright / chromium-plated parts with acid-free grease (Vaseline).
- Store the scooter in a dry room and jack it up so that its weight is not on the wheels



NOTE

Combine storage activities with an inspection by a dealer.

Recommission after storage

- Remove the preservation agents from the outside.
- Clean the scooter.
- Install the charged battery
- Preserve the battery terminals with terminal grease.
- Check / adjust the tire pressure.
- Check the brakes.
- Carry out activities according to the inspection plan.
- Carry out the safety checks.

SERVICE INSTRUCTIONS

Technical changes, accessories and spare parts

WARNING

Technical changes to the scooter can lead to cancellation of the warranty.

Should you want to make technical changes, observe Genuine Scooter Company guidelines. This will help to prevent the scooter from being damaged and ensure the operational safety of the scooter is retained. A specialized dealer can carry out these activities with meticulous care.

Always consult a dealer before buying accessories or making any technical changes.

CAUTION

We recommend using only approved accessories and original spare parts for our scooters.

This is in your own best interest: the safety, suitability and reliability of these accessories and parts will have been tested specifically for our scooters.

Although we keep track of the market, we cannot evaluate nor be held liable for the quality of non-approved accessories and parts, even if they have a certificate of acceptance from an originally recognized technical testing / supervision agency, or a license issued by the authorities.

For approved accessories and original spare parts, see a Genuine Scooter Company dealer. He/She will also ensure that they are professionally installed.

NOTES ON MAINTENANCE

Engine oil level

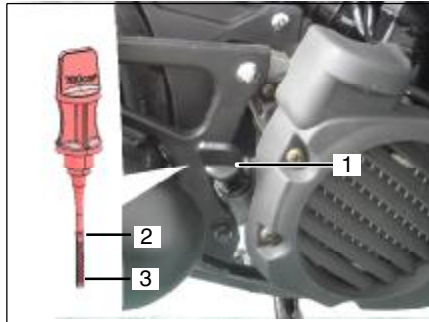

Checking the engine oil level

- Stop the warmed-up engine, wait for several minutes.
- Prop up the scooter on the parking stand.
- Remove the oil level plug(1) and check the engine oil level that should be between the minimum level mark(3) and maximum level mark(2).
- If below the minimum level mark(3), replenish recommended engine oil to the proper level.
- Stop warmed-up engine and check again
- Tighten the oil level plug

Changing the engine oil



Changing the engine oil level

- Stop the warmed-up engine, wait for several minutes.
- Prop up the scooter on the parking stand.
- Remove the oil drain bolt (1) and drain the engine oil.

CAUTION

Do not allow foreign materials to enter the crankcase

Clean oil filter element

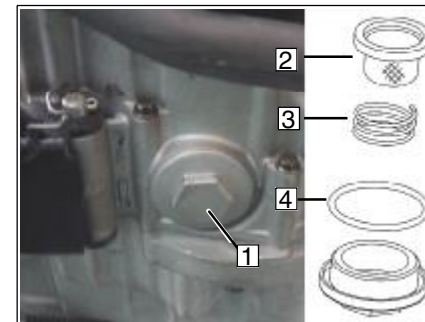

Clean oil filter element

If the oil filter element also needs to be replaced or cleaned, perform the following procedure.

- Remove the oil strainer cover (1), spring (3) and Oil filter element (2).
- Replace the O-ring (4).
- Install the new or clean oil filter element and the oil strainer cover.

NOTES ON MAINTENANCE

Fill engine oil

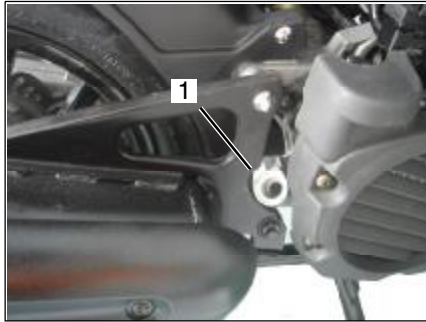

NOTE

Recommended:
**Engine oil grade: API service SG type
or higher**

Engine oil type: SAE 10W/40

Quantity: 0.78L

Transmission oil

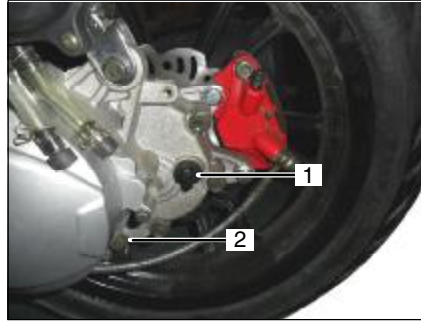

Checking the transmission oil level

- Stop the warmed-up engine, wait for approx. 5 minutes
- Prop the scooter on the parking stand.
- Remove the oil filler plug (1) and check if the oil level is below the oil-filler opening.
- If required, replenish transmission oil.

Changing the transmission oil

- Stop the warmed-up engine, wait for several minutes
- Prop the scooter on the parking stand.
- Remove the oil drain bolt (2).
- Drain the transmission oil (completely).
- Install the oil drain bolt (2).

Filling the transmission oil

- Remove the oil filler plug (1)
- Fill the transmission oil
- Install the oil filler plug (1)

Recommended:

**Transmission oil grade: API GL-4
or higher**

**Transmission oil type: SAE 80W/90
hypoid gear oil**

Quantity: 0.15L

Checking the steering bearings



 **NOTE**

The telescopic fork should not jam up when turned and it should swing back lightly to both end positions.

- Pull the hand brake to block the front wheel brake.
- Hold the handlebar with both hands and try to move the handle bar (1) back and forth.

If the fork column bearing shows noticeable play, it must be adjusted by a specialized dealer.

Checking the telescopic fork

- Pull the hand brake to lock the front wheel brake.
- Now pump the fork girders (2) several times up and down using the handlebar.
- The suspension should respond perfectly.
- Check the fork girders for oil leaks.

 **NOTE**

If damage to the telescopic fork or the spring strut is found, have the scooter examined by a professional dealer.

NOTES ON MAINTENANCE

Tire profile

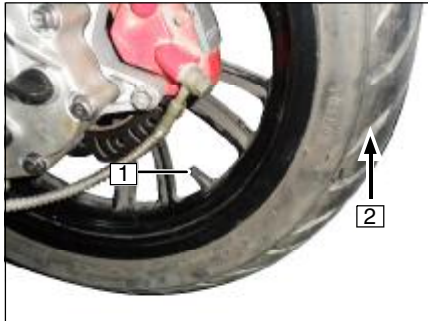

While the tires are cold:

- Twist off the valve caps:
- Check/adjust the tire pressure.
- Twist on the valve caps.

Tire pressure

Front 2.0 bar

Rear 2.25 bar

Tire size

The standard scooter is provided with the following tire sizes:

Front 100/80-16

Rear 120/70-14

Checking the tire profiles

⚠ WARNING

Observe the minimum profile depth prescribed by law.

Never ride without valve caps (1).
Firmly tightened valve caps prevent the tire from suddenly losing pressure.

- Measure the profile depth at the center (2) of the tire's tread.

Recommended minimum profile depth:
2.0 mm

Observe the wear marks (3).

Checking the tire pressure

⚠ WARNING

Adjust the tire pressure according to the total weight load. Never exceed the rated total weight or the bearing capacity of the tires.

Incorrect tire pressure will have a considerable effect on the riding properties of the scooter and the lifespan of the tires.

All tires are tubeless.

Front brake

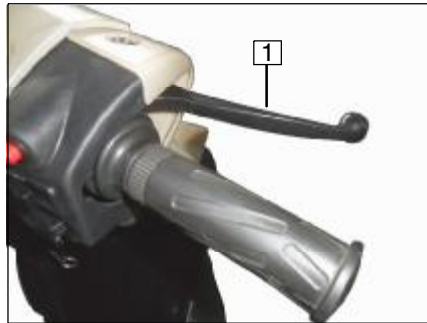

⚠ WARNING
Sudden changes in play or a spongy feel of the brake lever (1) can be caused by faults in the hydraulic system.

Front brake-fluid reservoir

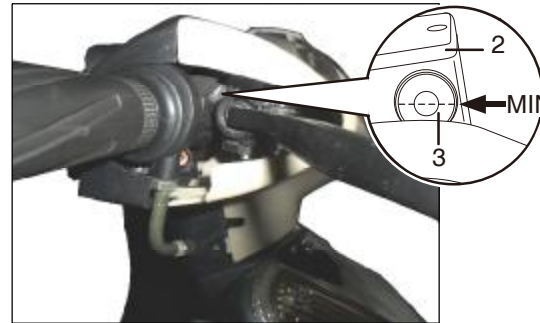

Checking the brake fluid

⚠ WARNING

Every two years, the brake fluid must be changed by a dealer. The level must not drop below the MIN mark. Use only brake fluid of the DOT 4 classification.

👉 CAUTION

Do not spill any brake fluid on painted or plastic surfaces as it will damage the scooter severely.

- Turn the handlebars until the brake-fluid tank (2) is level.
- The brake fluid level (3) should be between the minimum (MIN) and the maximum marking (MAX).
- If air bubbles can be seen, check the brake linings for wear; if necessary replenish the brake fluid by a dealer.

NOTES ON MAINTENANCE

Front brake system

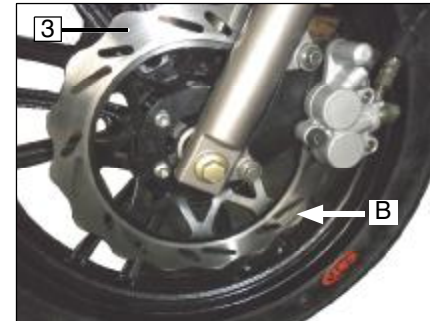
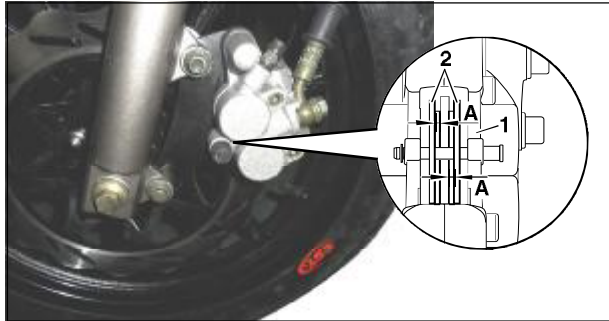

Checking the brake linings



CAUTION

The minimum lining thickness must be maintained.



NOTE

For your own safety, we recommend having activities to the brake system carried out by a dealer.

- Remove the protective cap (1) at the brake calliper.

- Visually inspect the sight glass (2) at the brake calliper.

- Check the thickness of the brake lining.

Minimum thickness: **A = 2.0 mm**

- If the lining thickness is below the minimum, **have the brake lining (2) replaced by a dealer.**

Checking the disc brake

- Visually inspect the disc brake (3).

- Check the thickness of the disc brake.

Minimum thickness: **B = 3.0 mm**

- If the disc thickness is below the minimum, **have the disc brake (3) replaced by a dealer.**

Rear brake system

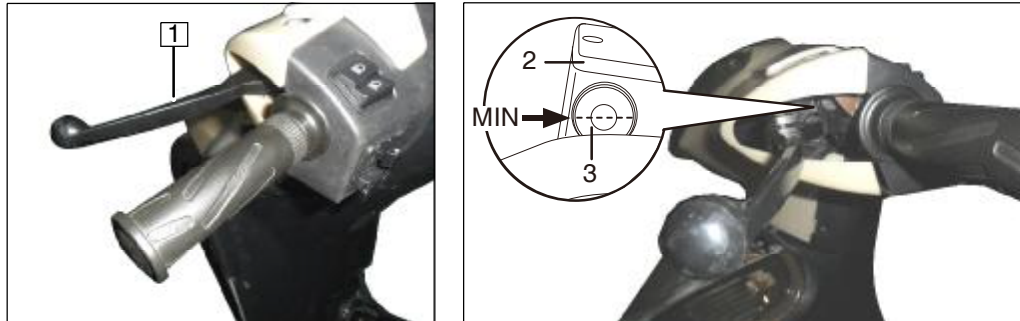

⚠ WARNING

Sudden changes in play or a spongy feel of the brake lever (1) can be caused by faults in the hydraulic system. If you notice low brake lever pressure, stop immediately using the front brake to inspect the brake system thoroughly.

Checking the brake fluid

⚠ WARNING

Every two years, the brake fluid must be changed by a dealer. The level must not drop below the MIN mark. Use only brake fluid of the DOT 4 classification.

👉 CAUTION

Do not spill any brake fluid on painted or plastic surfaces as it will damage the scooter severely.

- Turn the handlebars until the brake-fluid tank (2) is level.
- The brake fluid level (3) should be between the minimum (MIN) and the maximum marking (MAX).
- If air bubbles can be seen, check the brake linings for wear; if necessary replenish the brake fluid by a dealer.

NOTES ON MAINTENANCE

Rear brake system (continued)

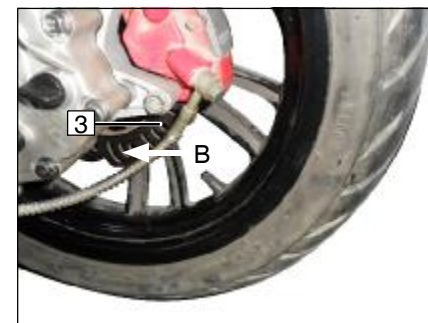
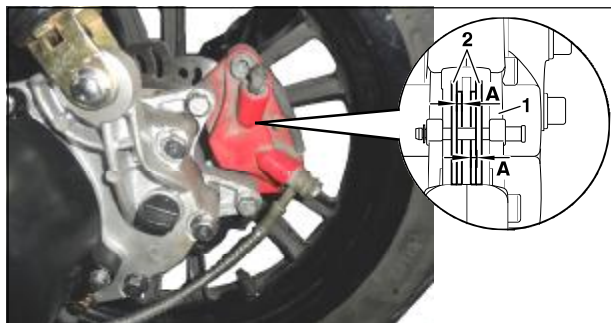

Checking the brake linings



The minimum lining thickness must be maintained.



For your own safety, we recommend having activities to the brake system carried out by a dealer.

- Remove the protective cap (1) at the brake calliper.
- Visually inspect the sight glass (2) at the brake calliper.
- Check the thickness of the brake lining.
Minimum thickness: **A = 2.0 mm**
- If the lining thickness is below the minimum, **have the brake lining (2) replaced by a dealer.**

Checking the brake disc

- Visually inspect the disc (3).
- Check the thickness of the disc.

Minimum thickness: **B = 3.0 mm**

- If the disc thickness is below the minimum, **have the disc brake (3) replaced by a dealer.**

Adjusting the play of the twist grip throttle control

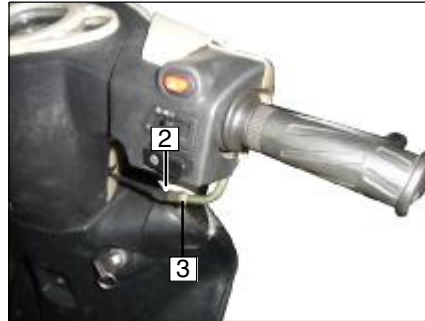
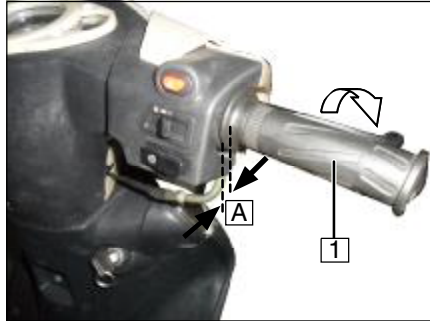

Check:

- Check the throttle cable for light movement by turning the twist grip (1) from closed to open position
- Move the handlebar to check whether the throttle cable moves freely.
- Check whether the throttle cable is obstructed by other parts.
- Open the twist grip throttle control until resistance can be felt.
- Measure the play.
Nominal value: **A = 1-2 mm**

Adjustment:

- Slacken the lock nut (3) on the handlebar.
- Turn the setscrew (2) accordingly.
- Tighten the lock nut (3).
- Check the play.



NOTE

If the play cannot be corrected this way, have the scooter checked by your dealer.

NOTES ON MAINTENANCE

Cleaning the air filter

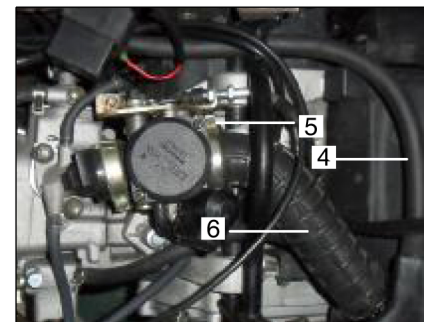
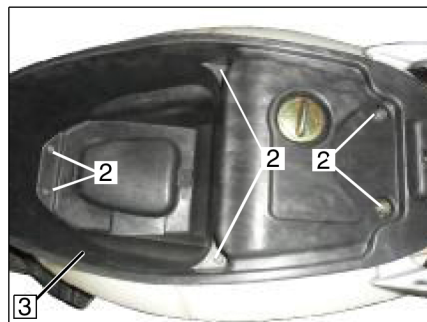

NOTE

The scooter is attached with an oil foam air filter. In case of heavy dirtiness the foam (1) has to be replaced.

Disassembly and cleaning

- Open the seat (1)

- Remove the bolts (2) and take off the storage box (3) together with the seat.

- Disconnect the hose (4) from the air filter housing.
- Remove the clamp (5) from the carburetor and disconnect the manifold (6).

Replacing the air filter

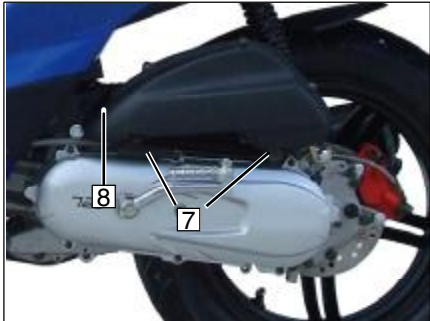

- Remove the screws (7) and take off the air filter housing (8)

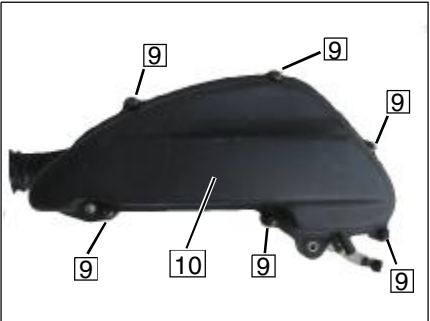

- Disassembly and replace**
- Remove the screws (9) and take off the air filter cover (10).
 - Remove the foam (11).
 - Check air filter element (12)
If damaged or dirty, replace.

 **NOTE**

Replace the air filter element every 7500 miles.

The air filter needs more frequent service if you are riding in unusually wet or dusty areas.



NOTES ON MAINTENANCE

Install the air filter



CAUTION

Never run the engine without an air filter.

- Dust deposit is one of the major causes of reducing output horsepower and increasing fuel consumption.
- Change the air cleaner element more frequently to prolong the engine's service life if the scooter is often ridden on dusty roads.
- Check for proper installation of the foam housing in the filter case.
- Otherwise the engine will run poorly or engine damage can occur.
- Be careful not to soak the air cleaner when washing the scooter. Otherwise the engine will be hard to start.



Installation



NOTE

Check the gasket for damage and proper placement before installation.

Installation takes place in reverse order from disassembly.

NOTES ON MAINTENANCE

Checking the spark plug

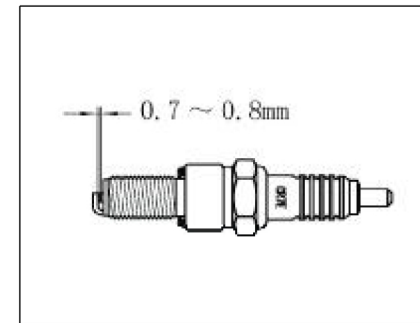
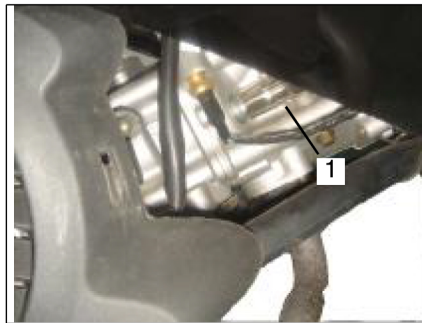

Check and change



CAUTION

Check or change the spark plug only when the engine is cold.



NOTE

The spark plug is accessible from the right-hand side.

- Pull the spark plug connector (1).
- Unscrew the spark plug with the spark wrench from the on-board toolkit.
- Check the electrode gap (0.7-0.8 mm), replace the spark plug if it is severely burnt away.
- Use a new spark plug **NGK CR7E** and tighten up.
- Screw in the spark plug by hand and then tighten up with the spark wrench.
- Plug in the spark plug connector (1).

NOTES ON MAINTENANCE

Checking the fuse

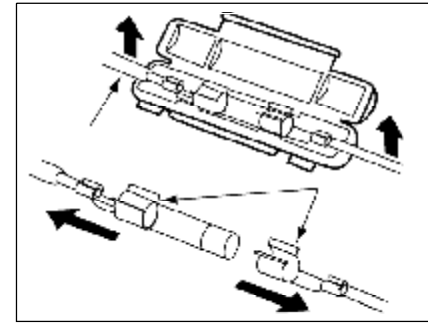
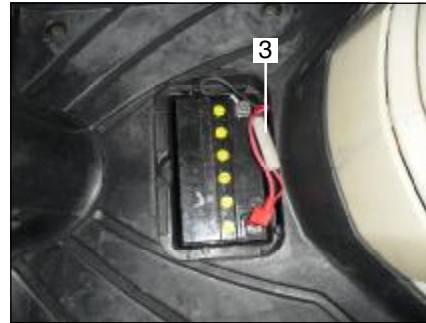
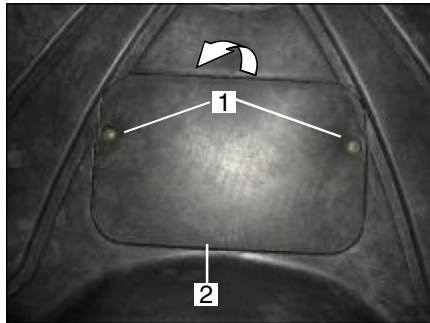

CAUTION

Never install a fuse with a larger rating, since this could destroy the entire electrical system.

The fuse is located behind the inspection cover (2).

- Turn off the ignition.
- Remove the two screws (1) and open the inspection cover (2).
- Open the fuse case (3) and remove the fuse.
- A faulty or blown fuse must be replaced by a new one with 15 A.
- Check the fuse for correct contact. Loose fuse will blow.

Installation takes place in reverse order to disassembly.

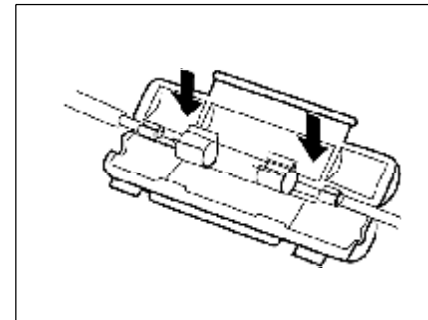

NOTES ON MAINTENANCE

Battery



WARNING

Always wear safety glasses. Keep children away from acids and batteries.



EXPLOSION DANGER

A battery being charged produces a highly explosive gas, which is why fire, sparks, naked flames and smoking are prohibited.



FIRE HAZARD

Avoid generating sparks / electrostatic discharges when handling cables and electrical devices. Avoid short circuits.



DANGER - CAUSTIC ACTION

Battery acid is highly caustic, so always wear safety gloves and glasses. Do not tilt the battery as acid can leak from the ventilation openings.



FIRST AID

If acid comes into contact with an eye, immediately flush the eye for several minutes with fresh water then immediately visit / call a doctor. Acid on the skin or clothing must immediately be neutralized using acid converter or soap suds, and the spots must be flushed with plenty of water. If acid is swallowed, immediately visit / call a doctor.



CAUTION

Do not expose batteries to direct sunlight. Discharged batteries can freeze, so they must be stored in a place where the temperature remains above 5 degrees - 15 degrees Celsius. Professional maintenance, charging and storage will increase the lifespan of the battery.



DISPOSAL

Take dead batteries to a proper collection point. Never dispose of batteries with household refuse.

Charging the battery

After a long lay-up (3-4 months), charge the battery. The charging current (in amperes) must not exceed 1/10th of the battery capacity (Ah).

The battery must not be fast-charged. The battery may only be charged using a special charger approved for MF batteries.

Maintenance

Although the battery is maintenance-free, never leave the battery discharged. Keep the battery clean and dry and make sure that the connection terminals are firmly seated.

NOTES ON MAINTENANCE

Removing and installing the battery

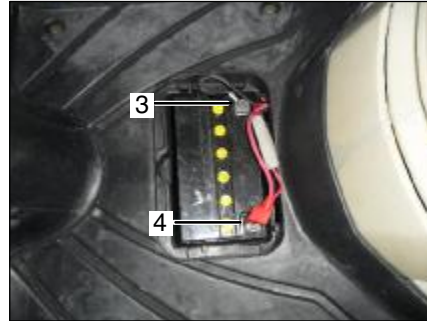
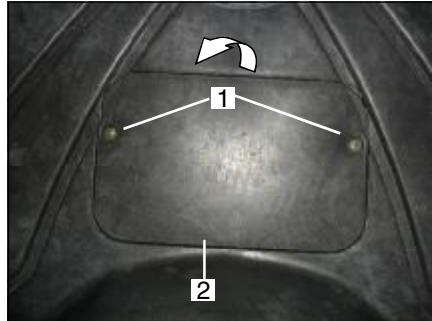

CAUTION

The battery may only be connected or disconnected while the ignition is inactive.

First disconnect the negative (-) terminal (3, black cable).

When installing the battery, first connect the positive (+) terminal (4, red cable).

The battery is maintenance-free. Do not attempt to open it.

- Turn off the ignition.
- Remove the two screws (1).
- Open the inspection cover (2).
- Disconnect the battery.
- Remove the battery.

Installation takes place in reverse order to disassembly.

Headlight and position light

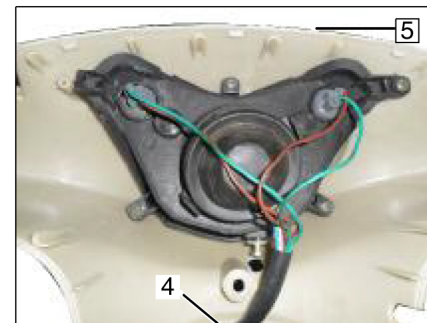
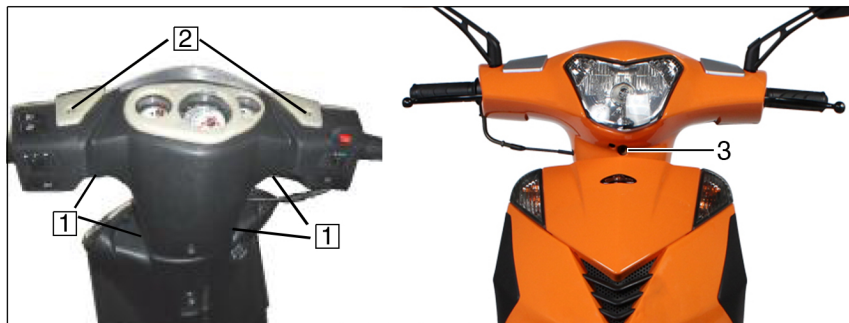

Changing the bulb



NOTE

Use only tested, incandescent bulbs with 'E' designation. Use of non-approved bulbs will void the operating license. Do not touch the bulbs with bare fingers. Hold bulbs with a clean, dry cloth when installing or removing them.

- Turn off the ignition.
- Remove the tapping screws (1).
- Remove the screws (2)
- Remove the screw (3)

- Disconnect the plugs (4).
- Take off the headlight cover (5).

Low beam - high beam

Bulb: **12V 35W**

Position light

Bulb: **12V 5W**

NOTES ON MAINTENANCE

Headlight and position light

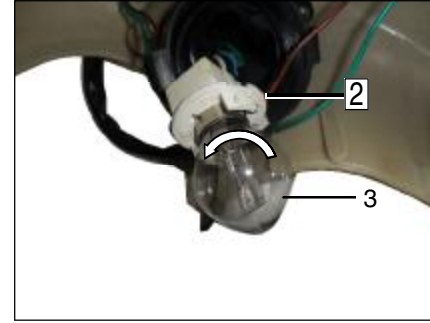
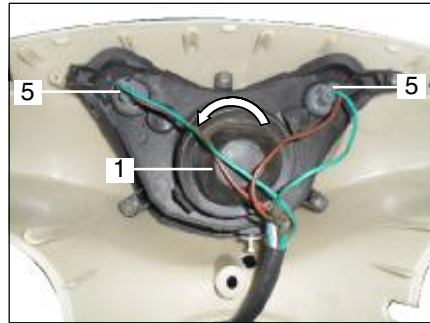

Low beam

- Remove the rubber cover (1).
- Remove the bulb socket (2) by turning to the left.
- Remove the head light bulb (3).

Installation takes place in reverse order to disassembly

Position light

- Remove the headlight.
- Pull the position light (5) with the bulb holder carefully out of the position light housing.

Front direction indicator

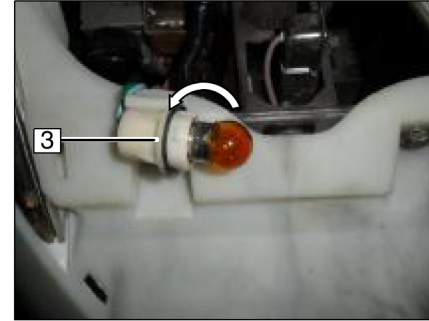
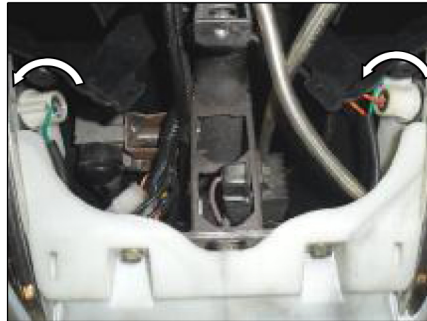

Changing the bulbs



NOTE

Do not touch the bulbs with bare fingers. Hold bulbs with a clean, dry cloth when installing or removing them.

- Remove the screws (1).
- Carefully remove the cover (2).
- Turn the lamp holder counter-clockwise and pull it out.

Installation takes place in reverse order to disassembly.

Bulbs: **12V 10W**

- Remove the bulb socket (3) and release it by pushing the bulb while turning counter-clockwise.
- Remove the bulb.

Installation takes place in reverse order to disassembly.

NOTES ON MAINTENANCE

Rear direction indicator/tail/brake lamp

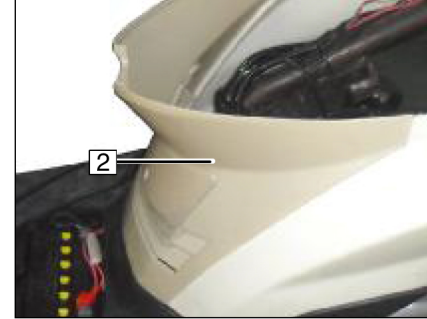
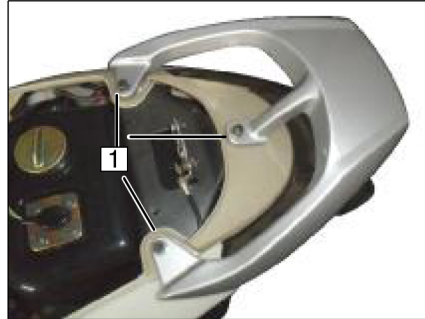

Changing the lamp.



NOTE

Do not touch the bulbs with bare fingers. Hold bulbs with a clean, dry cloth when installing or removing them.

- The rear direction indicator / tail / brake lamp is LED.

Please change the whole lamp.

- Remove the seat and storage box.
- Remove the bolts (1).

- Remove the covers (2).

NOTES ON MAINTENANCE

Rear direction indicator/tail/brake lamp

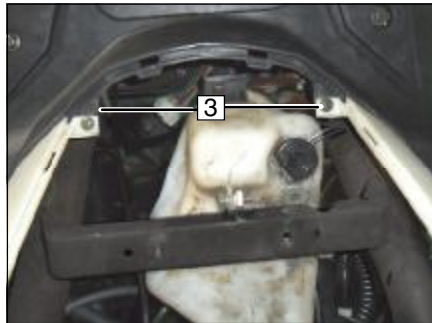

- Remove the screws (3).

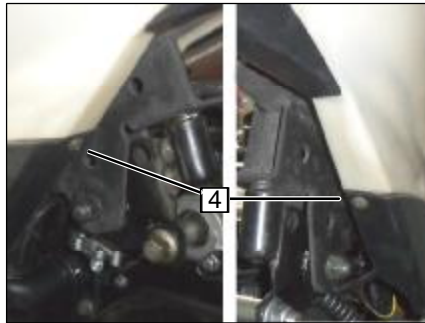

- Remove the screws (4).



- Carefully remove the cover (5).

NOTES ON MAINTENANCE

Rear direction indicator / tail / brake lamp

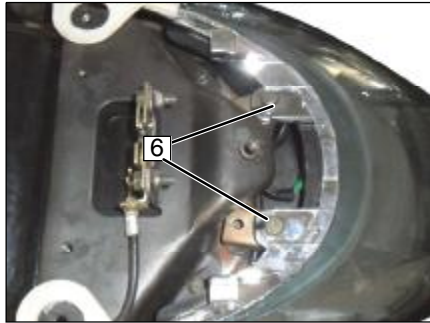

- Remove the bolts (6).

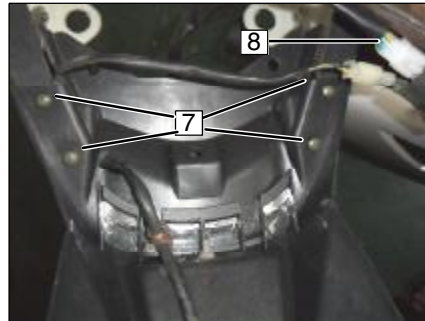

- Remove the screws (7).
- Pull the lamp connector (8).
- Carefully remove the tail / brake lamp.

- The rear direction indicator / tail / brake light is LED.

Please change the whole lamp.

Installation takes place in reverse order to disassembly.

Check the headlamps

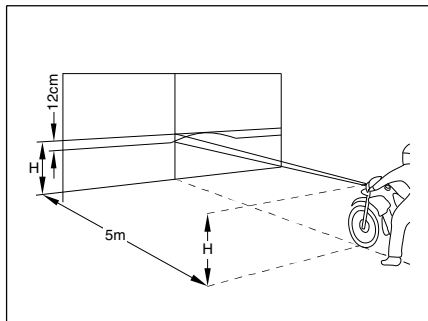

WARNING

Do not run the engine in an enclosed space (risk of asphyxiation).

Position the scooter on a level floor 5m (measured from the headlamp) from a light colored wall with a rider seated on the scooter and the tires filled at the correct pressure.

- Measure the distance from the floor to the center of the headlamp and mark the height on the wall with a cross. Draw a second cross 12 cm beneath the first cross.

Adjusting the headlamps



NOTE

If you have problems adjusting the headlamps, see a specialized dealer. An incorrect adjustment is punishable by law. Remember, you are responsible for the correct adjustment of the scooter's headlamp.

- Start the scooter and run the engine.
- Activate the dipped beam.
- Use a screwdriver to adjust the screws (1) for the vertical and horizontal angle of the illuminated surface area of the road top for the left and right headlamp.

NOTES ON MAINTENANCE

Engine type	LJ1P38MB
Construction:	One cylinder 4-stroke gas engine
Piston displacement:	49.3 cm ³
Bore:	38 mm
Stroke:	43.5 mm
Compression ratio:	12:1
Cooling:	Water cooling
Maximum net power output:	2.0 hp at 7000 rpm (restricted)
Maximum net torque:	1.5 ft-lb at 6500 rpm
Ignition system:	Transistorized ignition system with electronic ignition control (CDI)
Spark plug:	NGK CR7E
Electrode gap:	0.7 - 0.8 mm
Carburetor:	Deni PD18J
Idle speed:	1800 +/- 100 1/min
Air Filter:	Element air-cleaner
Starter:	Electric starter and kick starter

TECHNICAL DATA

Power transmission	
Clutch:	Centrifugal type
Transmission:	CVT
Coolant	Mixing ratio: 4:6 (antifreeze: water) Coolant reservoir capacity: 0.5 L
Chassis	
Scooter version:	Venture 50
Front suspension:	Telescopic fork
Rear suspension:	Unit swing, hydraulic shock absorption, adjustable preload
Wheels front:	Light metal (Alu) MT 2.15 x 16
Wheels rear:	Light metal (Alu) MT 2.75 x 14
Tires front:	100/80-16 tubeless
Tires rear:	120/70-14 tubeless
Tire pressure:	Front = 29 psi Rear = 33psi
Brakes, front:	Disc brake ø240 mm, hydraulic
Brakes, rear:	Disc brake ø193 mm, hydraulic

TECHNICAL DATA

Lubricants and operating fluids	
Fuel tank capacity:	6.8 Liters / 1.8 Gallons
Fuel:	Premium lead-free fuel (min. 93 octane)
Lubricating oil:	API service SG type or higher SAE 10W/40 quantity: 0.78 L
Gear oil: Filling quantity:	Hypoid-oil SAE 85W - 140 or SAE 80W-90 GL4 oil change: 0.13 litres / oil change + overhaul: 0.15 litres
Electrical Equipment	
Generator:	12V 120W
Battery:	12V 7Ah MF
Fuse:	15 A
Head light:	Low beam / High beam 12V 35W / 35W
Position light:	12V 5W
Instrument lights	
Speedometer:	12V 3W
Control lights indicator and high beam:	12V 3W
Brake/rear light:	12V LED
Front turn signal light:	2 x 12V 10W

TECHNICAL DATA

Dimensions and weights	
Overall length:	78.3 in
Width across handlebars:	27.6 inches without rear view mirror
Maximum height:	44.5 inches without rear view mirror
Wheel base:	56.6 in
Seat height:	31.5 in
Weight empty:	210 lbs
Weight in running order:	218 lbs
Max. permitted total weight:	553 lbs
Top speed:	30 mph (restricted)

Please observe the following:

- During and after the warranty period all inspections should solely be performed by a Genuine dealer.
- Observe the inspection intervals.
- Use only original spare parts.



CAUTION

In case of non-compliance the warranty will become null and void.

The various activities carried out are listed on the inspection plan.

During the warranty period the following inspection intervals must be complied with:

At	500 Miles (1 st service)
Every	1500 Miles or after 6 months
Every	3000 Miles or after 12 months



WARNING

For safety reasons, do not alter or adjust the scooter components or chassis in a manner that exceeds design restrictions. Tinkering with safety-relevant parts could threaten the safety of yourself and others.

This applies especially to the exhaust system, carburetor, ignition system, fork column, brake system and lights.

Before starting work on the electrical system, disconnect the negative terminal of the battery.

INSPECTION PLAN

I = Inspection, cleaning, and adjustment R = Replacement C = Cleaning (replaced if necessary) L = Lubrication					
Component Assembly	Before each trip	1st service after 500 miles	Every 1500 miles / 6 months	Every 300 miles / 12 months	Every 7500 miles / 24 months
Air cleaner (foam filter)	I	I	I		R
Fuel filter	I	I	I		R
Spark plug	I	I	I		R
Ignition time		I	I		
Carburetor (Idle speed)	I	I	I		
Throttle cable adjustment	I	I	I		
Transmission oil	I	R	I	R	
Transmission check for leakage	I	I	I		
Crankcase check for leakage	I	I	I		
Crankcase ventilation		I	I		
Drive belt, roller			I	I / R	
Clutch discs			I	I / R	
Engine oil	I	R	R		
Engine oil strainer		C		C	
Coolant level	I	I	I		R

INSPECTION PLAN

I = Inspection, cleaning, and adjustment R = Replacement C = Cleaning (replaced if necessary) L = Lubrication					
Component Assembly	Before each trip	1st service after 500 miles	Every 1500 miles/ 6 months	Every 300 miles/ 12 months	Every 7500 miles 24 months
Bolts and nuts (engine)	I	I	I		
Exhaust system		I	I		
Fuel tank, fuel hoses	I	I	I		
Battery	I	I	I		
Steering and bearings	I	I	I		
Front and rear suspension	I	I		I	
shock absorption	I	I		I	
Tire pressure	I	I	I		
Brake function, brake pads	I	I	I		
Brake fluid	I	I	I		R / every 2 years
Main- and side stand	I	I	I / L		
Bolts and nuts (chassis)	I	I	I		

MAINTENANCE CONFIRMATION

500 Miles / 1 months
1st service
dealer stamp:

mi.....
date

After 1500 Miles / 6 months
dealer stamp:

mi
date

After 3000 Miles / 12 months
dealer stamp:

mi
date

After 5000 Miles / 18 months
dealer stamp:

mi
date

After 7500 Miles / 24 months
dealer stamp:

mi
date

After 10,000 Miles / 30 months
dealer stamp:

mi
date

After 12,500 Miles / 36 months
dealer stamp:

mi
date

After 15,00 Miles / 42 months
dealer stamp:

mi
date

MAINTENANCE CONFIRMATION

New brake fluid
Yes no

mi.....
Date

Stamp, signature

New brake fluid
Yes no

mi.....
Date

Stamp, signature

New brake fluid
Yes no

mi.....
Date

Stamp, signature

New brake fluid
Yes no

mi.....
Date

Stamp, signature